

Serial n° :  
Nominal range :  
Cable length : 10 meters +



## GENERAL FEATURES

Water level measurement, control and process for tanks and water towers.

## TECHNICAL PRINCIPLE

The level measurement is performed through the differential pressure measurement between liquid surface and the submersible sensor. The pressure is converted into electric signal by piezo-electric gauge to provide a 4/20mA output signal on 2 wires.

## MECHANICAL SPECIFICATIONS

Housing : Stainless steel 316L, PVC tip  
Cable : 2 wires + internal tube in shielded PVC (food approval) cable  
Sensor : piezo-resistive gauge with silicone coating.  
Diameter : 31 mm  
Height : 150 mm (without cable)  
Weight : 435 g (without cable) *Supplied normally with 10 meters of shielded cable (475 g) or more upon request*  
Fitting : by the suspension cable supplied with a hanging system KITCAB.

## ELECTRICAL SPECIFICATIONS

Output signal : 4/20mA output signal on 2 loop wires, 4mA for 0m and 20mA for the full-scale  
Power supply : Voltage supply between 6 to 38 volts DC input. *(Don't forget to integrate the voltage drop-out in the current loop)*  
Check the voltage specification of the protector unit  
EMC Conformity : EN 50 081-2, EN 50 082-2  
Consumption : the signal value (mA)

## TECHNICAL DATA

Water column range : Full-scale (F.S.) between 0,5 m to 30m. *(Full-scale 20mA adjusted to the required value by Hitec)*  
Equivalent pressure : 0,05 to 3 bars.  $P(\text{bars}) = H(\text{meters}) / 10.197$   
Hysteresis : 0,10 % F.S. *(constant temperature)*.  
Non-linearity : 0,15 % F.S. *(constant temperature)*.  
Temperature operating range : from 2°C to 50° Celsius

## USING INSTRUCTIONS

Electrical connections:

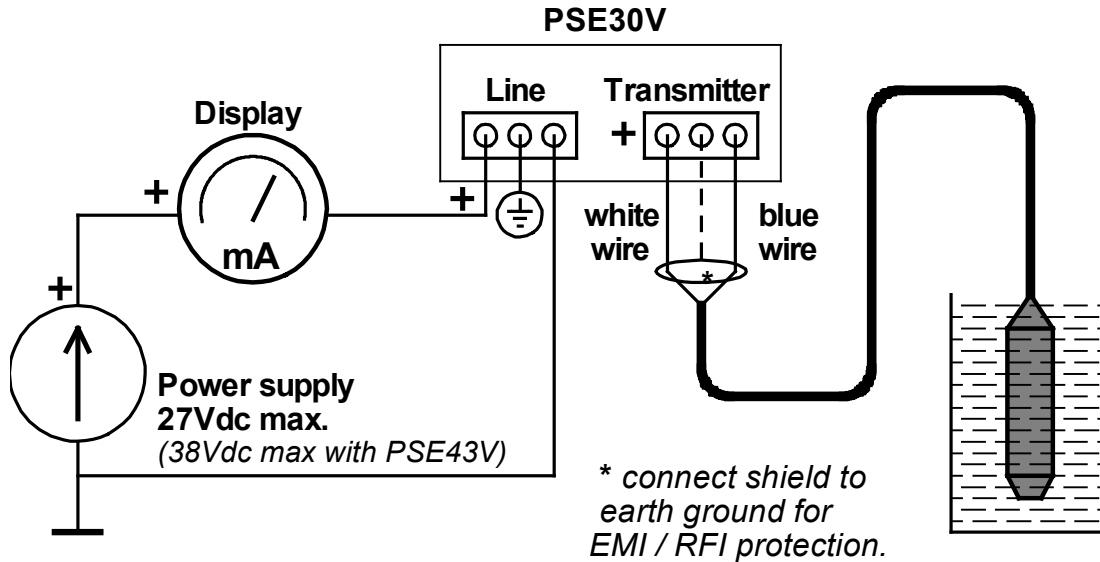

The operating instructions are very easy. No need signal adjustment (fitted in laboratory)

The cable is fitted with an internal small tube for atmospheric pressure compensation. Don't block or pressure the tube. Don't put the end of the cable in water or flooding area during the installation, check the correct position of the cable without dangerous roughness or sharpness. Don't use any sharp tool for fitting: risk of water infiltration.

Check the correct polarity of the connections : the inversion of polarity is not destructive; in this case, the signal drops to 0mA.

Connect the lightning protector (PSE30V) on a very good earth line. Provide a power voltage supply sufficient to compensate the drop-out in the current loop and be sure to get a 6VDC minima on the transmitter : Measure the total electrical resistance of the line (included all electronic systems) and apply the following formula :

$$U \text{ (supply mini)} = 6V + (R \text{ line} \times 0.02 \text{ A}).$$

In the most cases, a 12 or 24 VDC supply is sufficient

**Warning** : Following the lightning protector unit fitted with the transmitter, **PSE43V** or **PSE30V**, the power voltage max. is **38V** for PSE43V and **27V** for PSE30V.

## TROUBLE-SHOOTING PROCEDURE

Transmitter checking : Disconnect the transmitter from the system ; Connect the transmitter on a battery (12VDC or small square 9VDC battery) and introduce a milli-ampere meter in the loop. Check the current value : 4mA with the transmitter out of water and atmospheric pressure, and 20mA for the full-scale height of water.

For intermediate value :  $H \text{ (meter)} = (\text{Signal (mA)} - 4\text{mA}) \times \text{F.S. (meter)} / 16,$   
and conversely :  $\text{Signal (mA)} = ((\text{Height (m)} / \text{F.S. (m)}) \times 16) + 4\text{mA}$